

VERSIONS

DRIVES

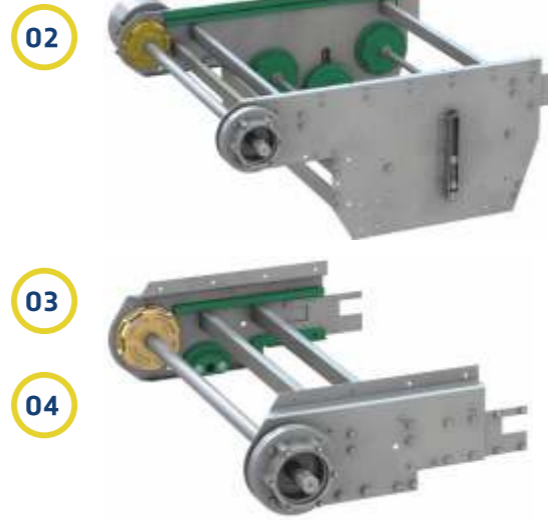

	01	02	03	04
	Front drive with 1,5 kW motor	Mini drive mobile unit with 0,75 kW motor	Mini drive on lift with 1,5 kW motor	Mini drive on lift with 0,75 kW motor
Motor	Flat gear motor SK 2282 AZ 90L/4	Flat gear motor SK 1282 AZ 80L/4	Flat gear motor SK 1282 AZ 90L/4	Flat gear motor SK 1282 AZ 80L/4
Power	1,5 kW, 64 U/min, 230/400V, 50/60Hz	0,75 kW, 82 U/min, 230/400V, 50/60Hz	1,5 kW, 69 U/min, 230/400V, 50/60Hz	0,75 kW, 69 U/min, 230/400V, 50/60Hz
Belt speed	26,4 m/min	33,8 m/min	28,4 m/min	28,4 m/min
Conveyor length	max. 40 m	max. 15 m	max. 30 m	max. 15 m

TECHNICAL DATA

- » drives: flat gear motors from 0,75 to 1,5 kW
- » belt speeds: 26.4 - 33.8 m/min (depending on motor)
- » system width: 750 mm
- » transport capacity: 10 animals per running meter of conveyor
belt weighing 2.0 kg (264 to 338 animals per minute)
- » maximum incline or decline: +/- 20°

SUITABLE COMPLEMENT

Cleaning Unit | Curve Conveyor | Steep Conveyor "Climber"

LUBING
POULTRYTEC

LUBING Maschinenfabrik GmbH & Co. KG
Lubingstraße 6 | 49406 Barnstorf
Germany

T +49 (0) 54 42 98 79 - 0
F +49 (0) 54 42 98 79 - 33
M info@lubing.de

LUBING.COM

As of: May 2026 | We reserve the right to make technical changes, further developments and improvements.
No. 0892-1

LUBING
POULTRYTEC



**BROILER CONVEYOR
FOR TAKING OUT THE
BIRDS FROM CAGES**

BROILER CONVEYOR

The LUBING broiler conveyor has been developed for the reliable and safe removal of poultry from cages. The conveyor is based on the proven LUBING conveyor technology from the egg transport sector. In order to meet the special requirements during animal transport, the design of the Conveyor-System has been optimized in many details. Special attention was paid to the avoidance of shearing points in order to ensure injury-free transport of the animals.

The broiler conveyor is moved in the stall by a lift system in order to be able to reach the different tiers of the cage system. The necessary length compensation is realized by moving the drive. The removal of the birds within the cage system is usually carried out by the manure belt. This minimizes the personnel required to remove the animals from the cage. The broiler conveyor is available as a stationary or flexible, mobile version (see diagram).

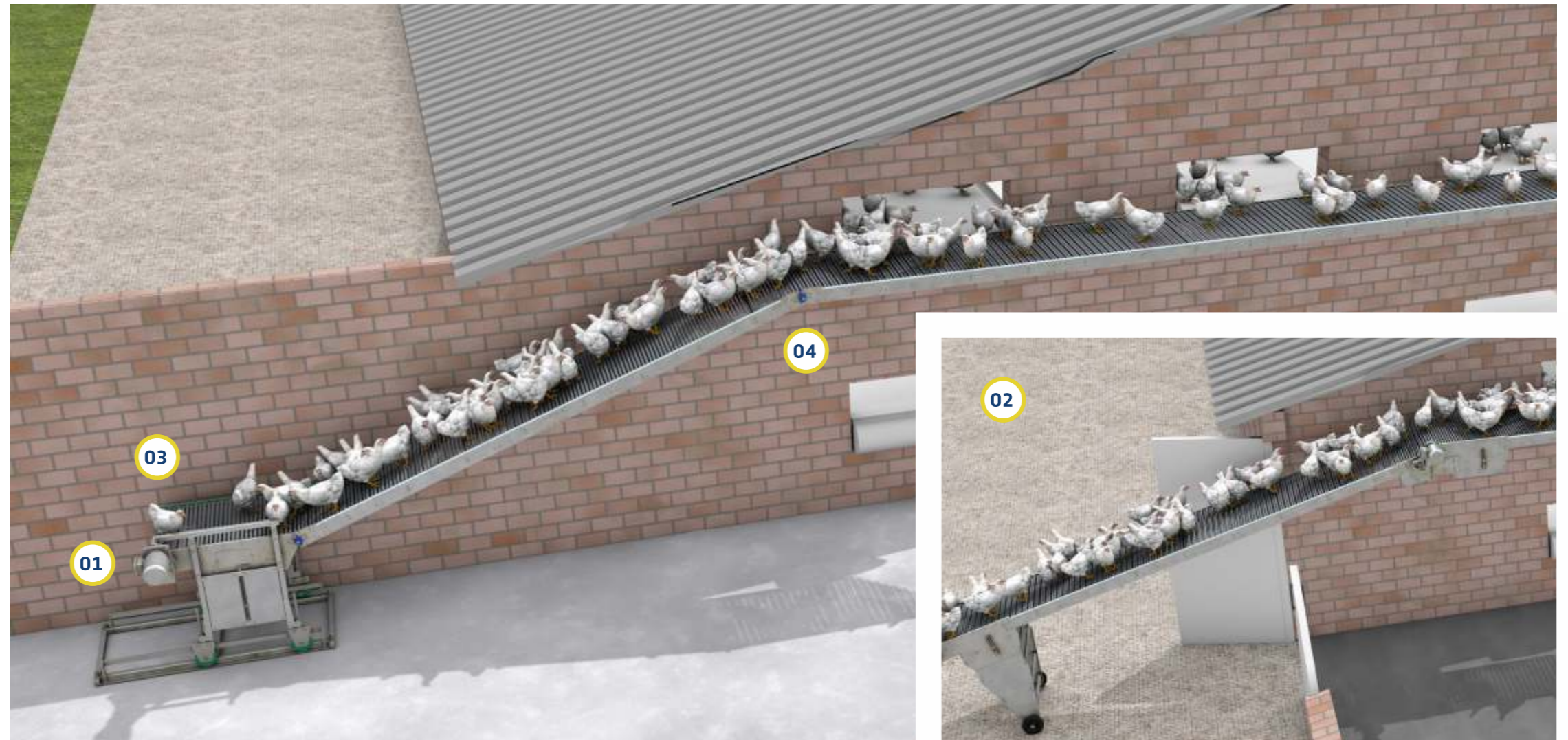

STATIONARY CONNECTING UNIT

- » installation as a fixed unit in the house area
- » up to 40 m total length due to solid front drive
- » frame bolted to the floor for safe movement of the drive unit
- » height level exactly adjustable by integrated threaded spindles
- » lift system for approaching the cage tiers



MOBILE CONNECTING UNIT

- » subdivision into two sections: Straight broiler conveyor with short drive (permanently installed on the lift system in the house) plus mobile unit (is hooked into the short drive during stall-out)
- » no large anteroom and no permanent opening in the side wall of the barn required
- » can be used for stall-out from different houses
- » easy connection and locking
- » space-saving storage when not in use



PROTECTIVE ELEMENTS

- » prevent the animals from being caught and thus ensure safe transport
- » conveyor chain reinforced by plastic elements provides a safe hold for the animals



PIVOTING UNIT

- » enables the approach of different floors by means of lift system

ADVANTAGES

- » Lift system for adapting the conveyor to different cage levels.
- » Mobile or stationary variants can be used.
- » Use of the manure belt as a feeder to the broiler conveyor.
- » Safe, injury-free transport of animals due to protective elements and shear point prevention.
- » Plastic-reinforced chain provides animals with perfect grip - even on slopes / inclines.